

**The
Revolving Disc Cooler “RDC”
A giant leap in clinker cooling with
unbeatable logic!**

Revolving Disc Cooler “RDC” - A smart concept

CemProTec

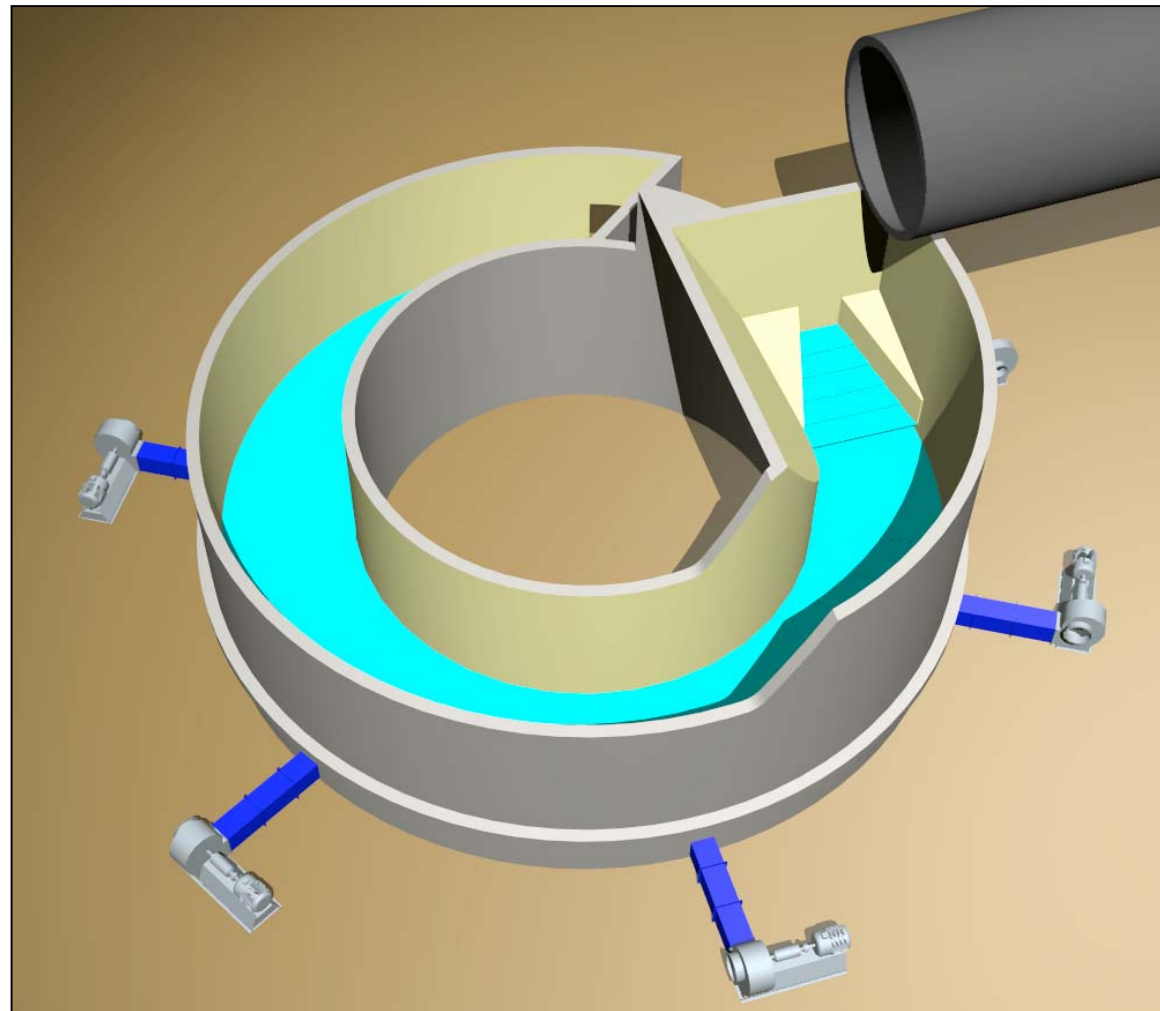

Revolving Disc Cooler “RDC”

CemProTec

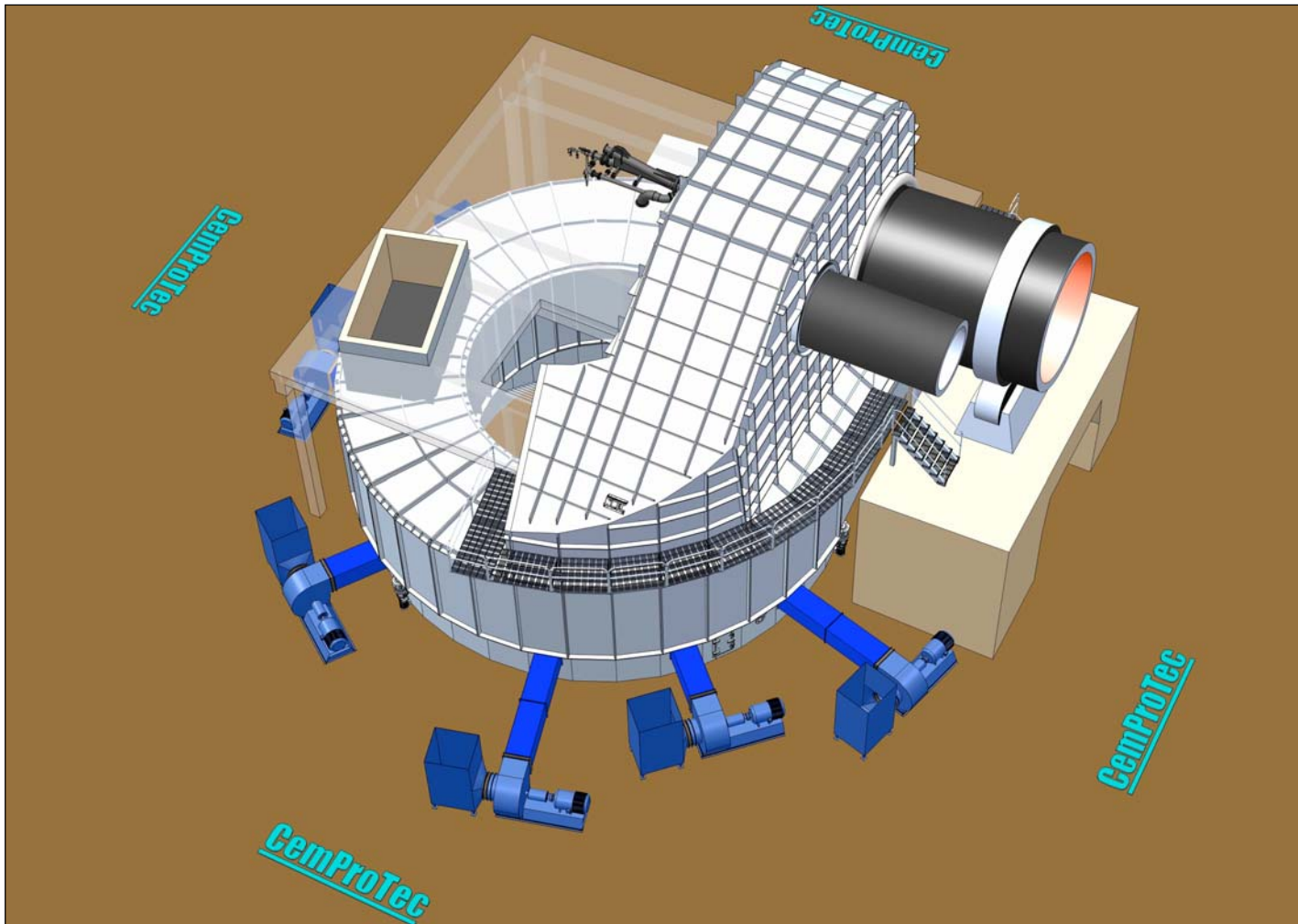

Revolving Disc Cooler “RDC”

CemProTec

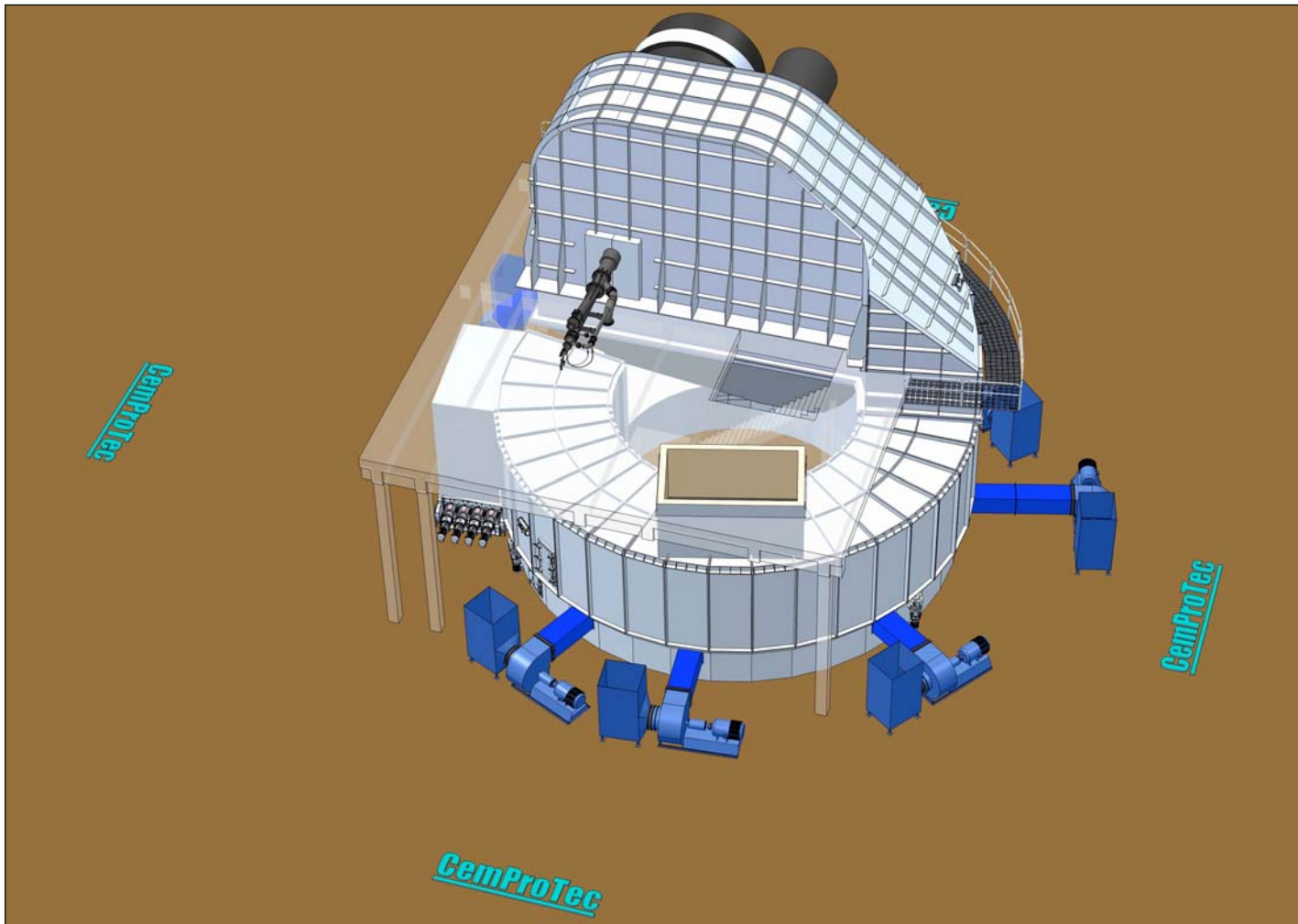

Revolving Disc Cooler “RDC”

CemProTec

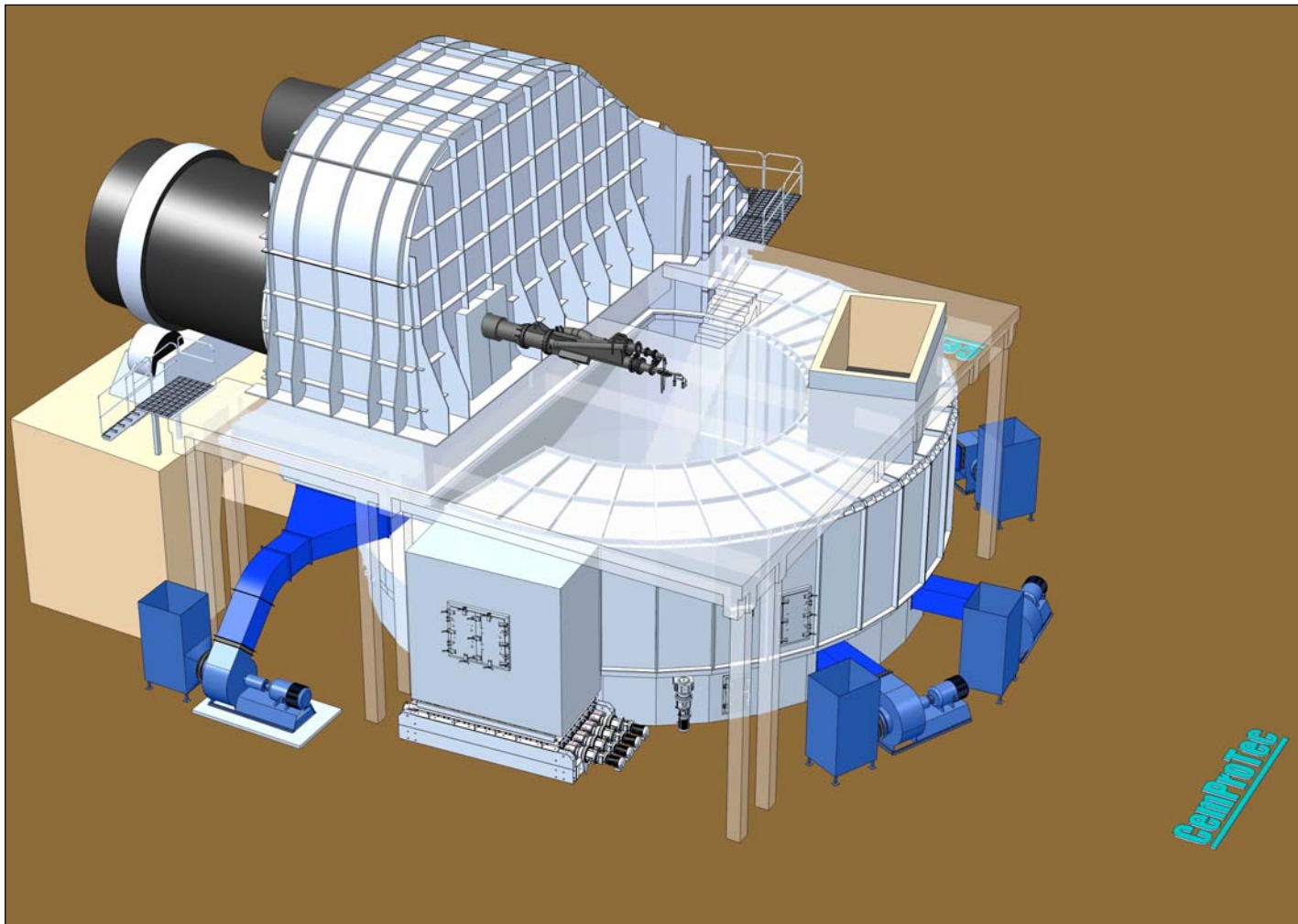

Revolving Disc Cooler “RDC”

CemProTec

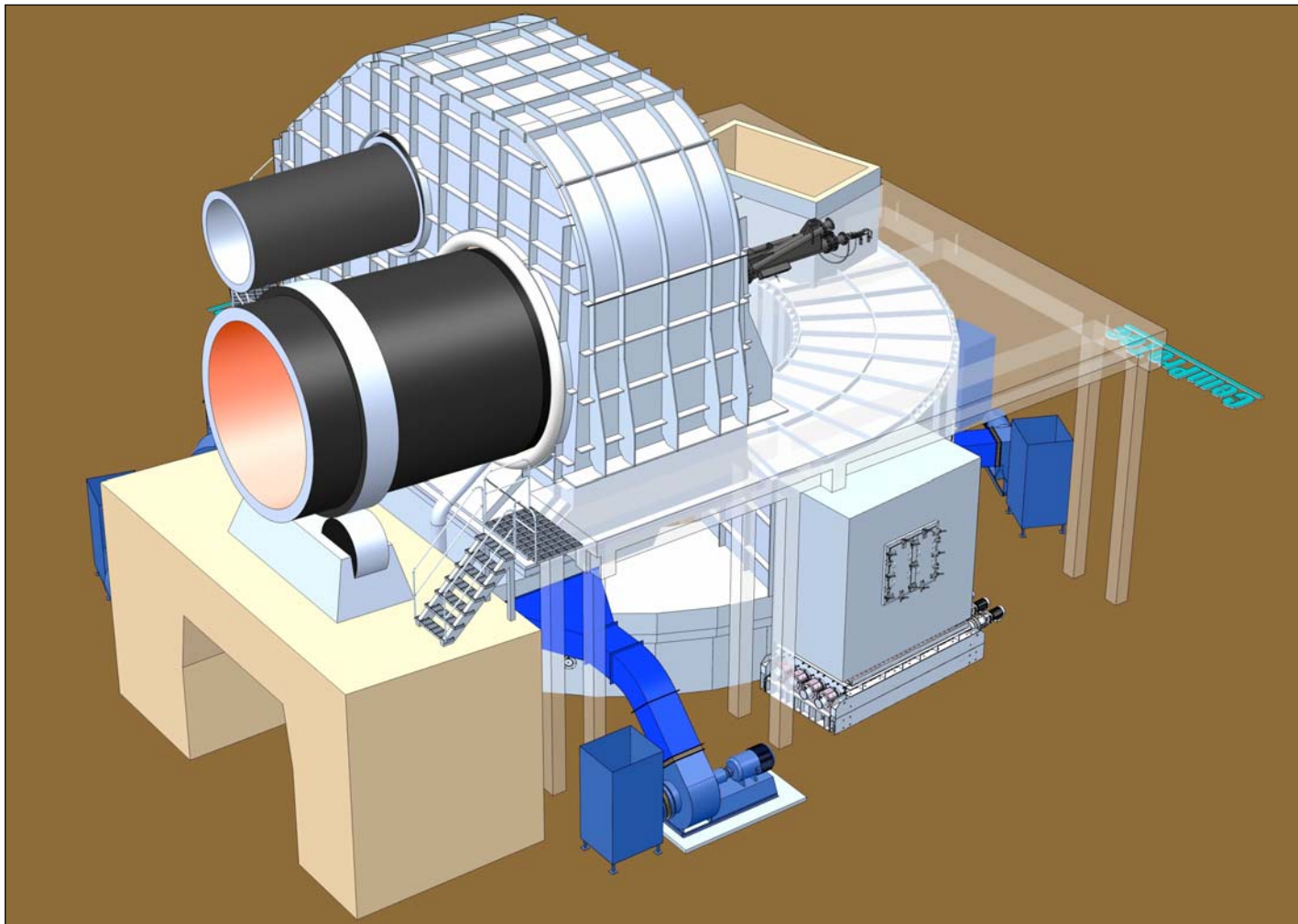

Revolving Disc Cooler “RDC”

CemProTec

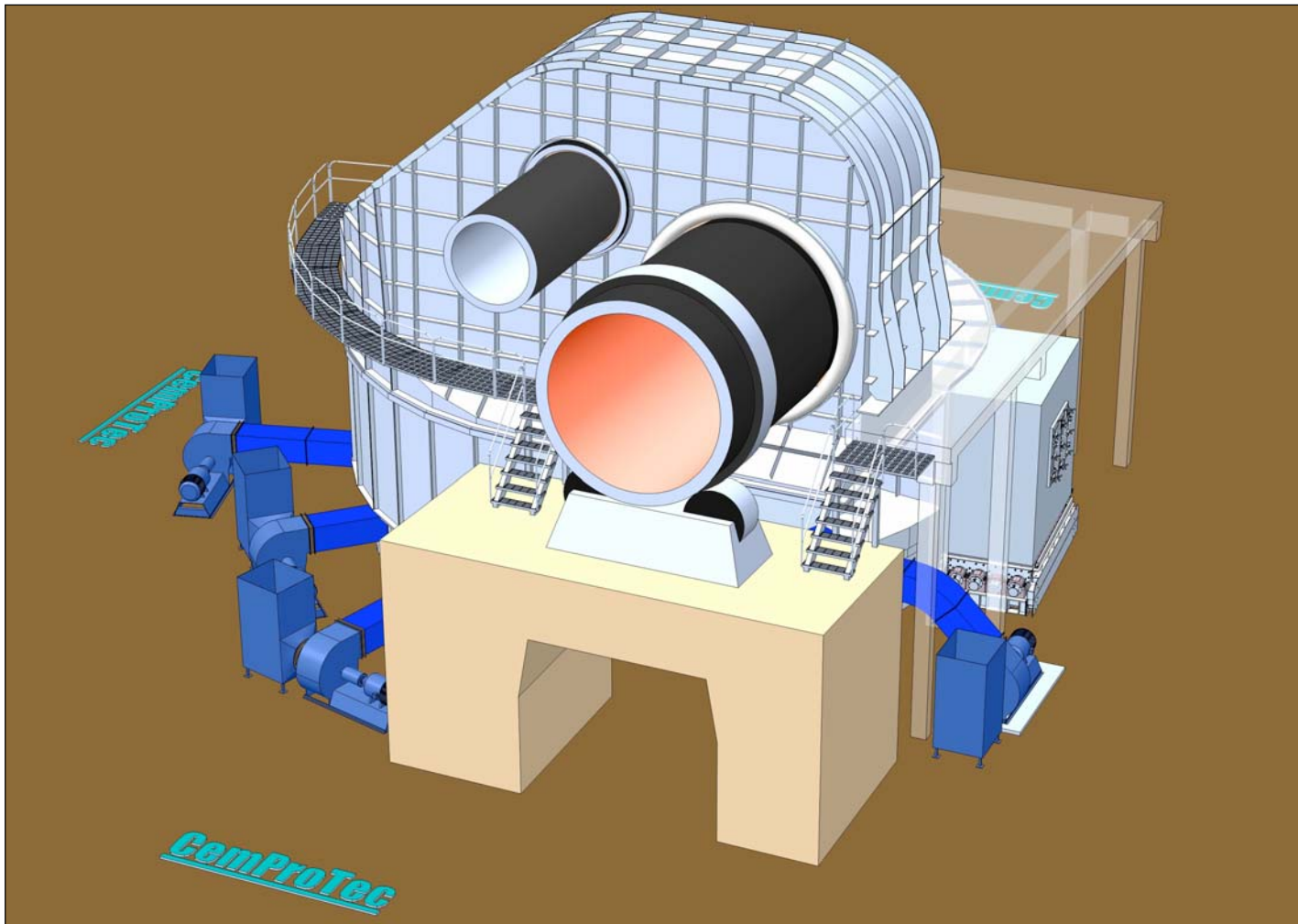

Revolving Disc Cooler “RDC”

CemProTec

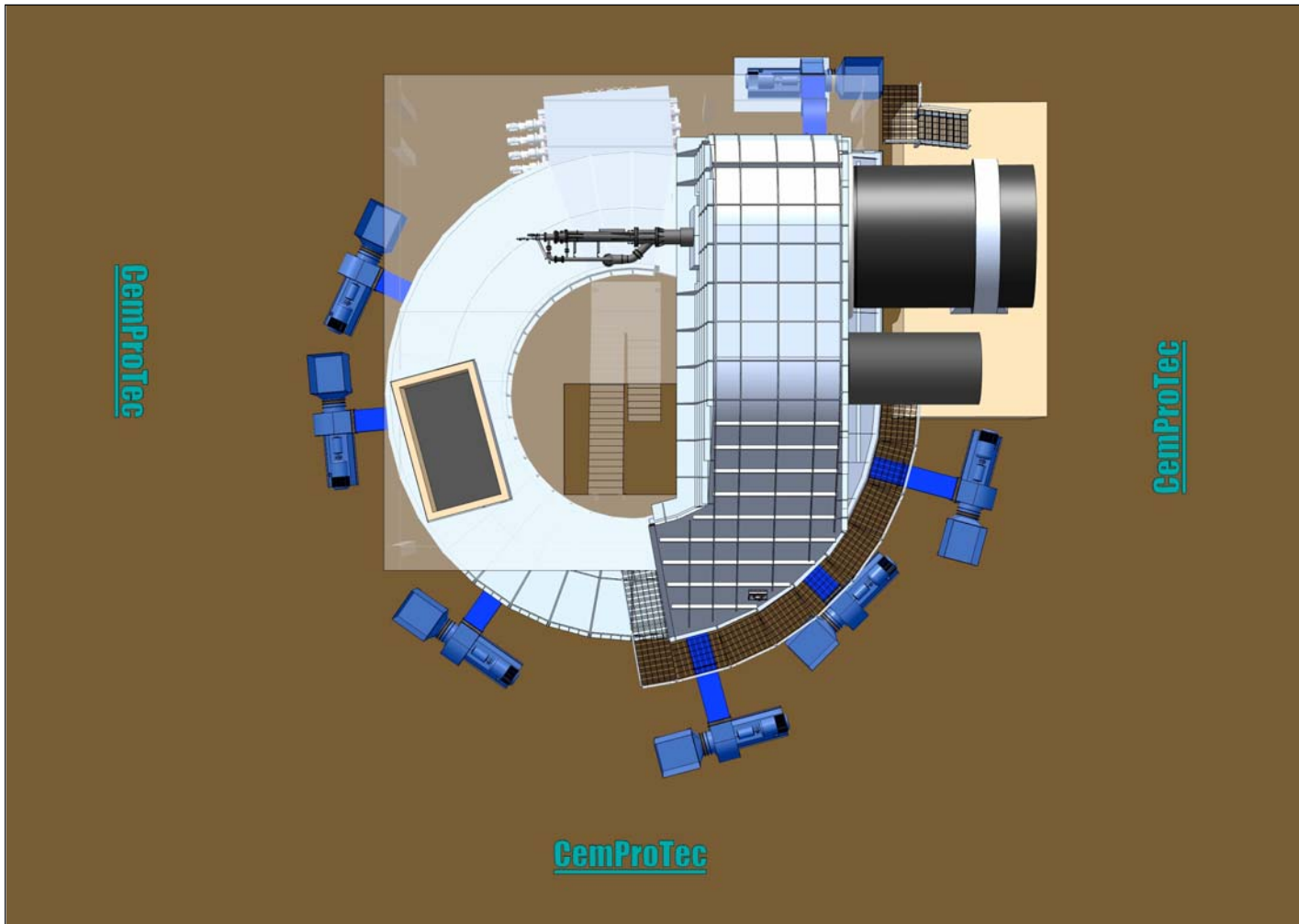

RDC - A Smart Concept

CemProTec

- **Simple and unique clinker cooler concept**
- **For any kiln capacity**
- **100% transport efficiency**
- **Highest process efficiency - Perfect cross flow heat exchanger**
- **Low cooling air volume and hence exhaust air**
- **Huge kiln hood but short burner**
- **Design flexibilities for optimum gas velocities**
- **Electrical drive for continuous motion**
- **CDS and Smart Blades are proven**
- **Perfect access for maintenance in transition zone**

RDC - A Smart Concept

CemProTec

- **No stop and go on static grate!**
- **No grate wear due to dead clinker layer**
- **No reciprocating movements**
- **No cylinders**
- **No flow regulators**
- **No vertical gaps**
- **No spillage**
- **No hoppers, chains, sector gates, etc.**
- **No wear between movable and fixed grate rows**
- **No maintenance underneath the grate, since the life of the bearings last for many years**